

Automatic Door Closer Installation Manual

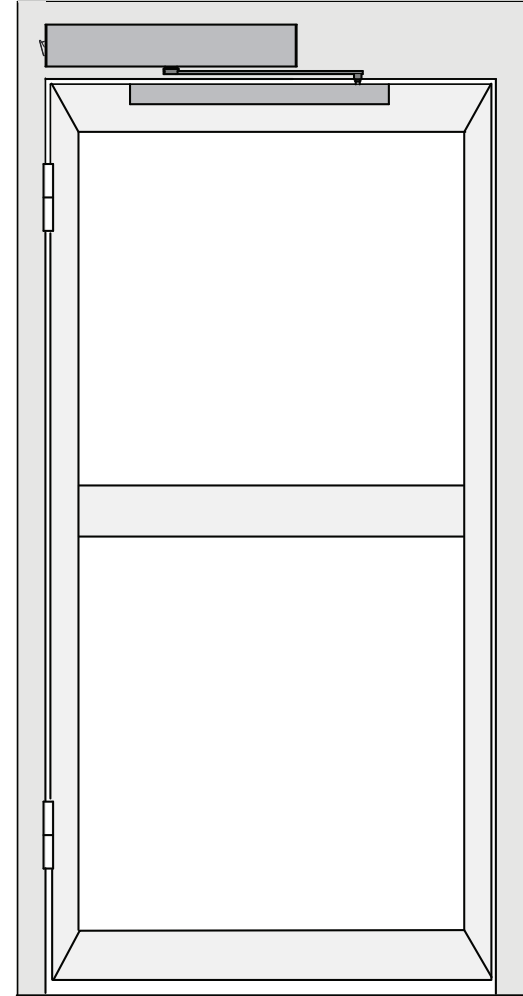

ASSA ABLOY



Product introduction

Door body form: Single door / double door

Scope of application: Pedestrian door set

Types of suitable doors: solid wood door / wooden frame glass door

/ aluminum frame door / stainless steel door

supply voltage: AC100-240V 50-60HZ

Power consumption: $\leq 120W$

Opening time: 4-10S(Adjustable)

Hold open Duration: 1-30S (Adjustable)

Resistance sensitivity: 5 Adjustable levels

Door opening and closing speed: 3 Adjustable levels

Mute requirements: the operating noise shall be less than 60 dB

Applicable door weight: 40-250kg

Applicable door thickness: 40-100mm

Suitable door width: 700-1600mm

Manual opening force: $\leq 25N$

Applicable temperature: $-30\sim 50^{\circ}C$

Opening times: 500000 times

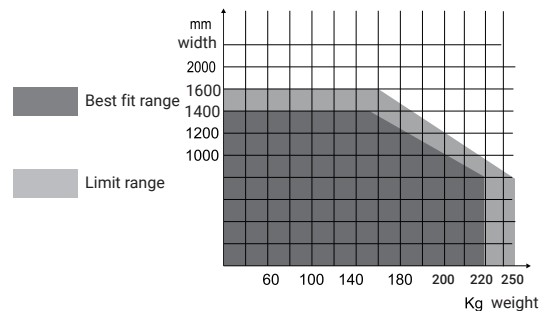

02

Product parameters

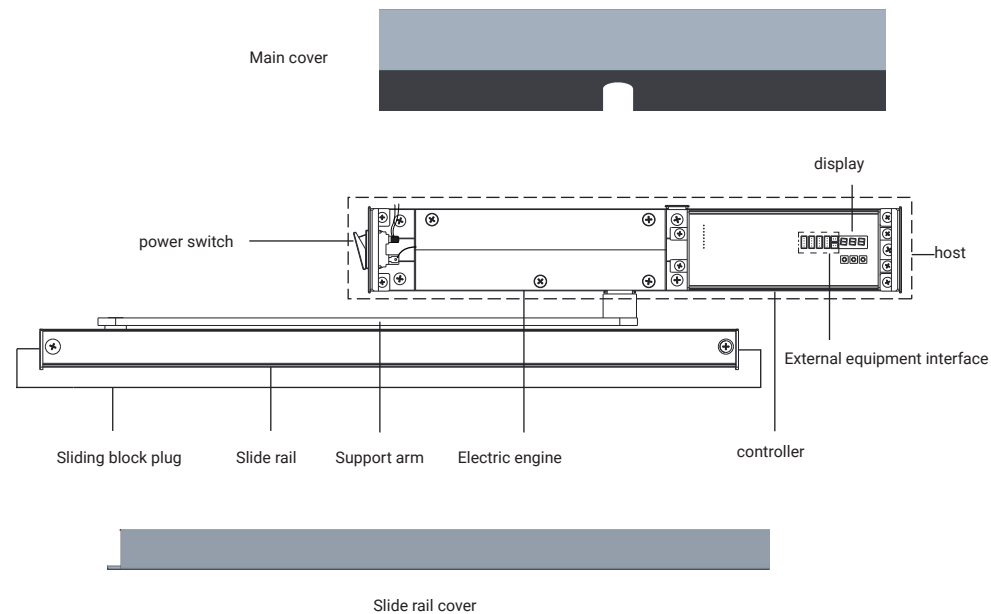

Note: When using facial recognition access control,

an external power supply is required, and it is prohibited to take power from the door opener

External induction: After the electric lock is opened, the external induction should fail

Anti pinch: During the door closing process, when there is an anti pinch signal, the door leaf opens

Collision prevention: During the opening process of the door, when there is a collision prevention signal, the door leaf stops and does not move (invalid if it is greater than 70°)

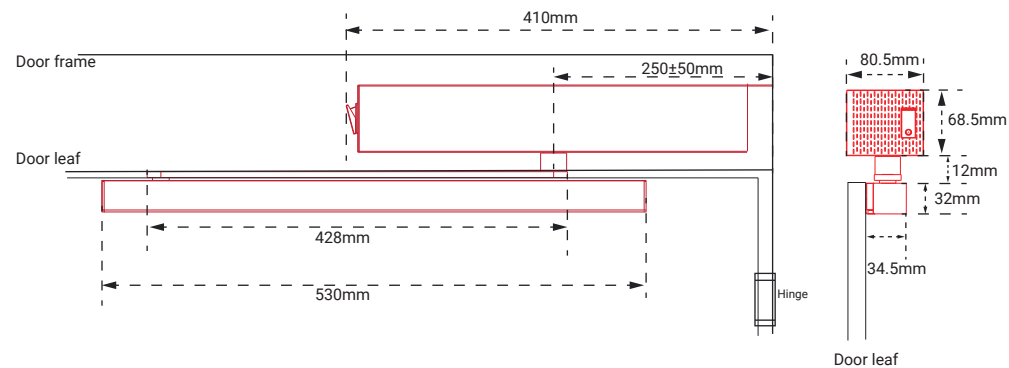
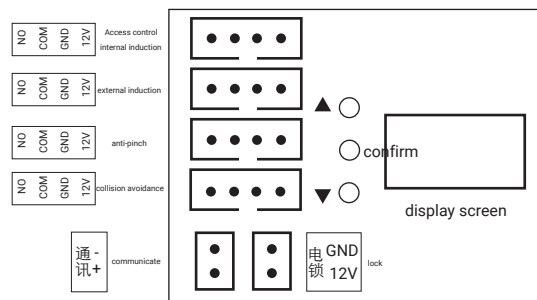

Installation guide for surface mounted door opener

Method for judging straight and curved arms

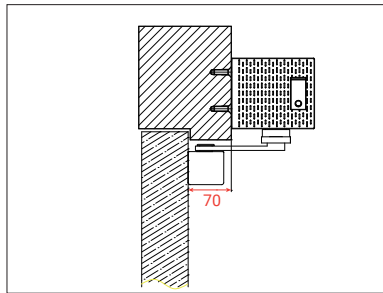

When the door opener is installed with external installation and internal opening, it is necessary to contact the manufacturer to replace the standard arm with a push arm when it exceeds the size shown in the figure above.

Scenario 1: Interior decoration and interior opening. (The flight crew is inside, and the door opens towards the inside of the room)

External installation and opening. (the crew is outside, and the door is open towards the outside of the room)

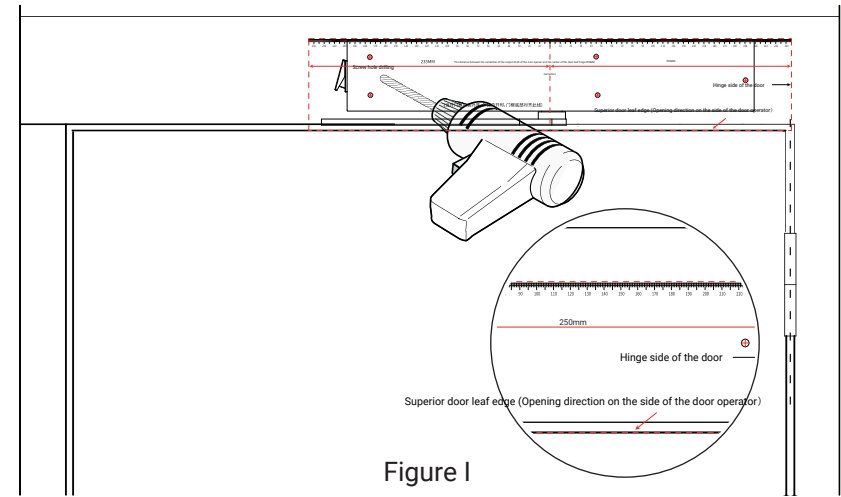
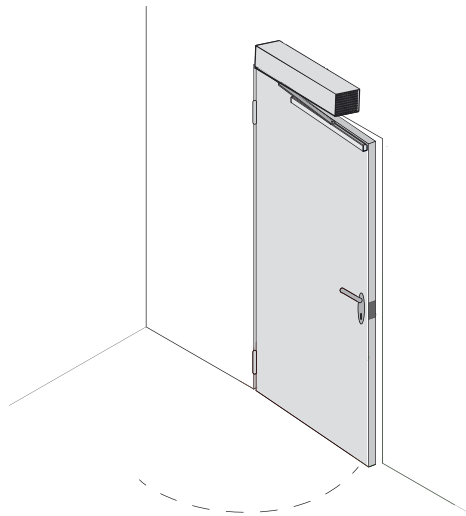

Figure 1

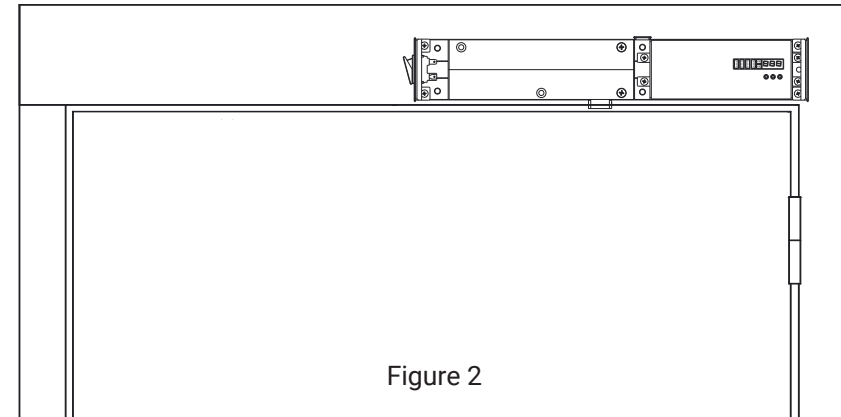

Figure 2

Installation steps

Step 1: When the door is internally opened or externally opened, place the installation card on the door frame, aligning the upper edge of the door leaf with the upper edge line of the card leaf, aligning the end of the card paper with the center of the hinge, and opening the

corresponding fixing screw holes, as shown in Figure 1.

Step 2: put the door opener on the door frame, align the already punched screw holes, and fix them with screws.

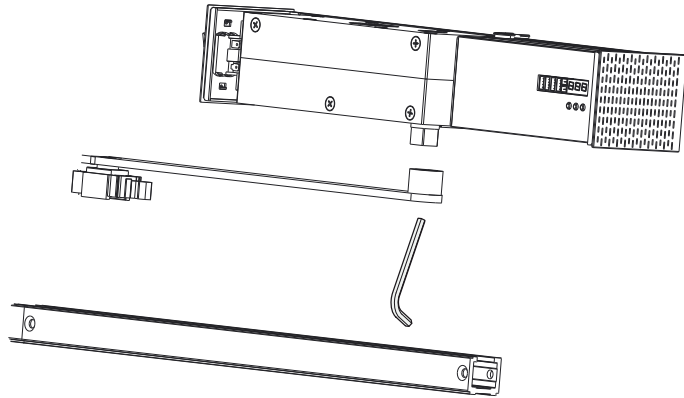

Figure 3

Step 3: fix the support arm on the door opener with hexagon socket, and pass the slide rail through the slider on the support arm, as shown in Figure 3.

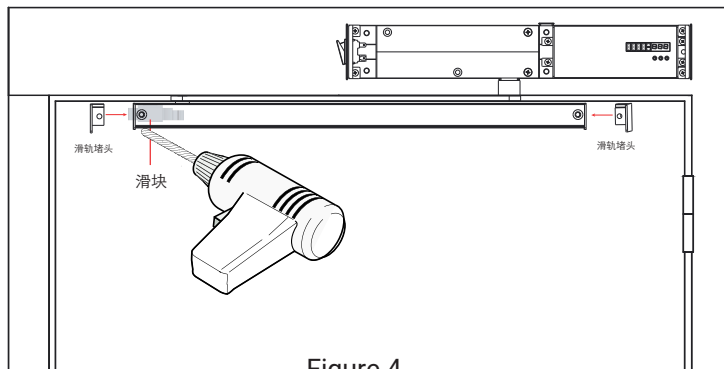

Figure 4

Step 4: Close the door, install the slide rail plug, and place the slider at the end of the slide rail, as shown in Figure 4. Then mark the screw hole position, open the hole, and fix the screw.

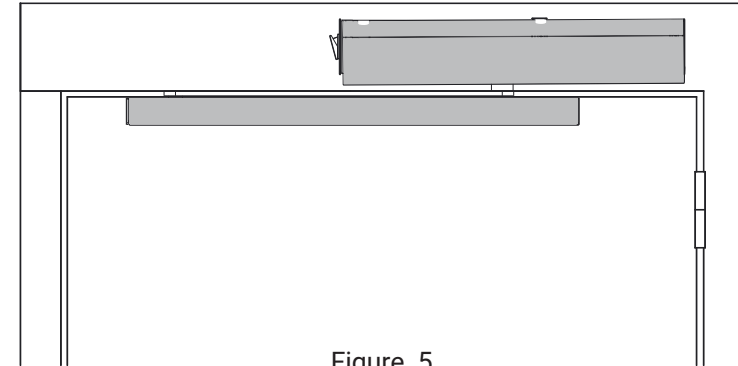

Figure 5

Step 5: connect the power, place the cover, as shown in Figure 5.

Step 6: the automatic door opener is debugged. Download the app first. See the product debugging instructions for debugging.

Scenario 2: interior installation and outward opening. (the operator is inside, and the door is open towards the outside of the room)

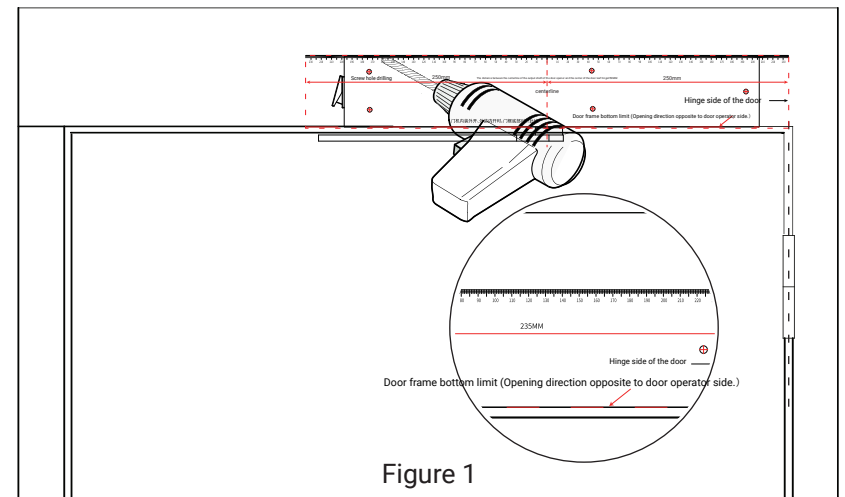
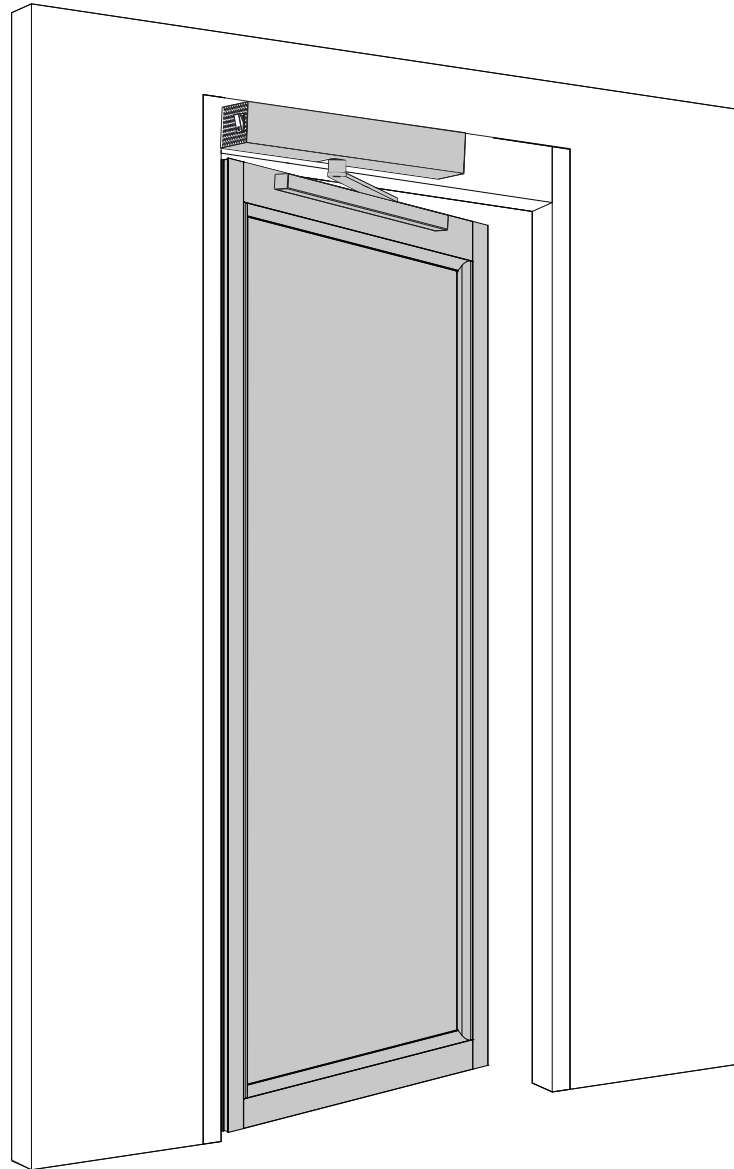

Figure 1

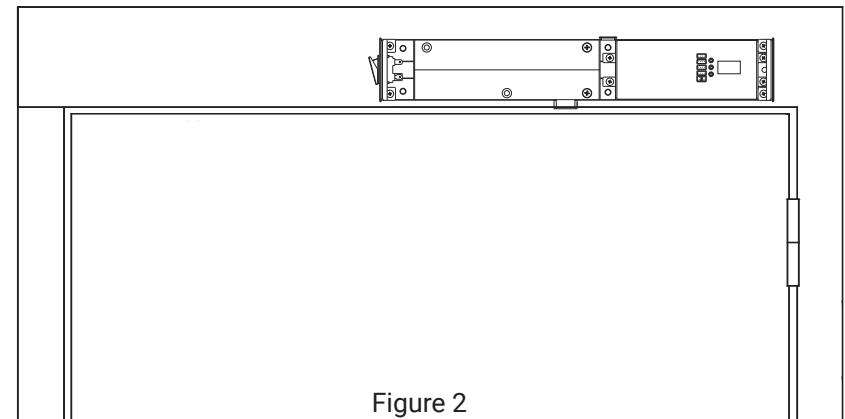

Figure 2

Installation steps

Step 1: When the door is internally opened or externally opened, place the installation card on the door frame, aligning the upper edge of the door leaf with the upper edge line of the card leaf, aligning the end of the card paper with the center of the hinge, and opening the corresponding fixing screw holes, as shown in Figure 1.

Step 2: put the door opener into the door frame, align the already punched screw

holes, and fix them with screws.

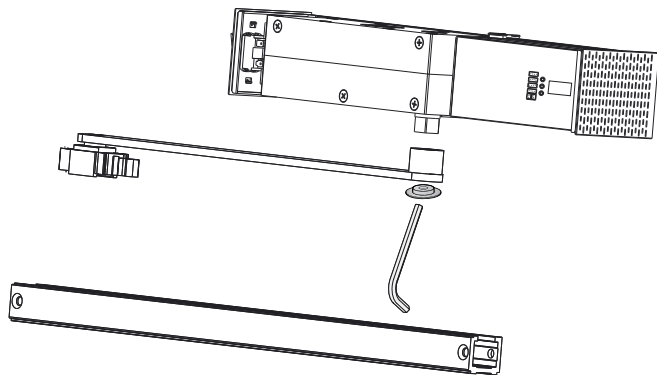

Step 3: fix the support arm on the door opener with hexagon socket, and pass the slide rail through the slider on the support arm, as shown in Figure 3.

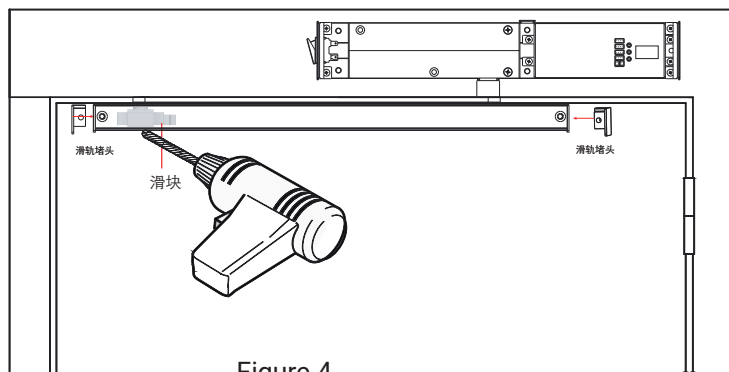

Figure 4

Step 4: Close the door, install the slide rail plug, and place the slider at the end of the slide rail, as shown in Figure 4. Then mark the screw hole position, open the hole, and fix the screw.

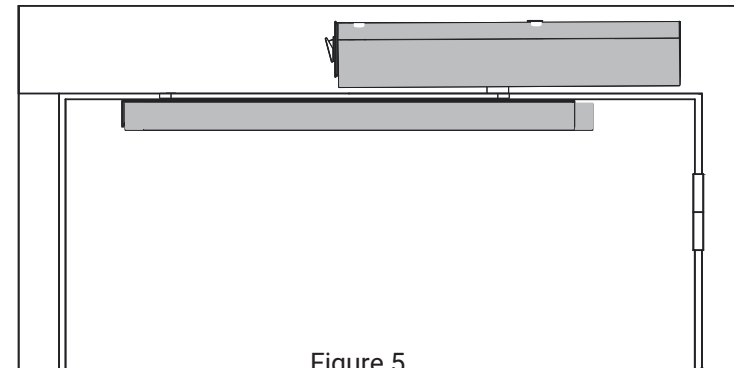

Figure 5

Step 5: connect the power, place the cover, as shown in Figure 5.

Step 6: the automatic door opener is debugged. Download the app first. See the product debugging instructions for debugging.

Scenario 3: installation method of push arm.

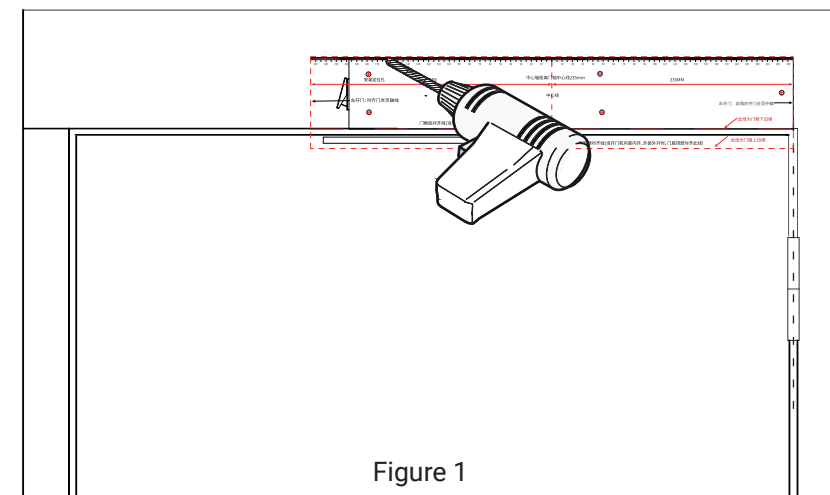

Figure 1

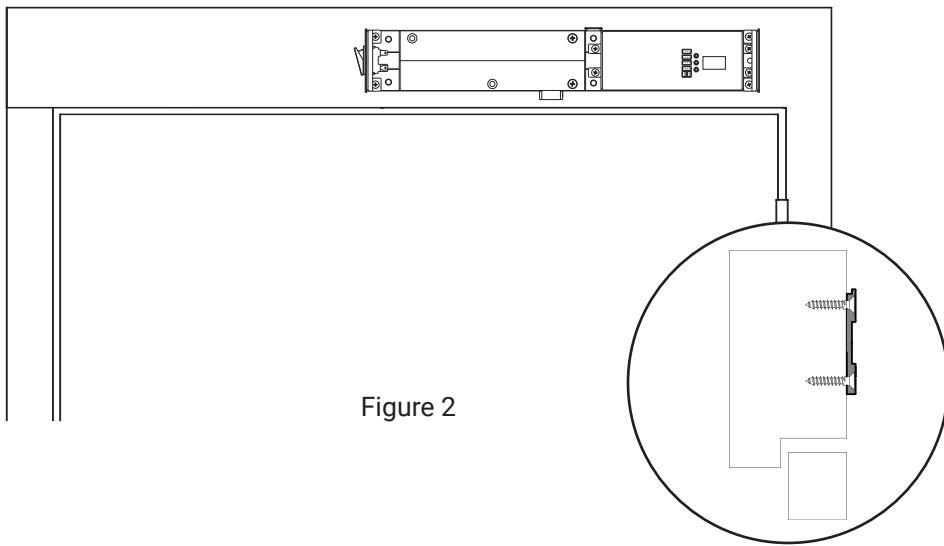

Figure 2

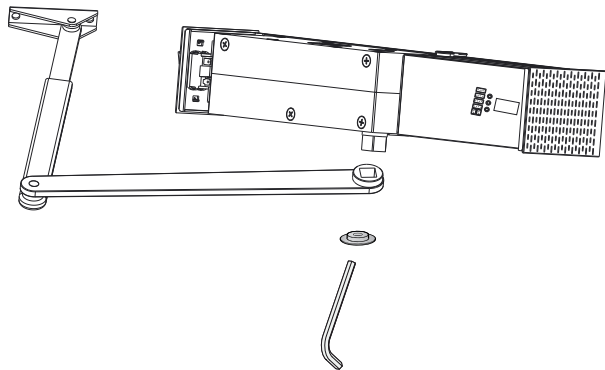
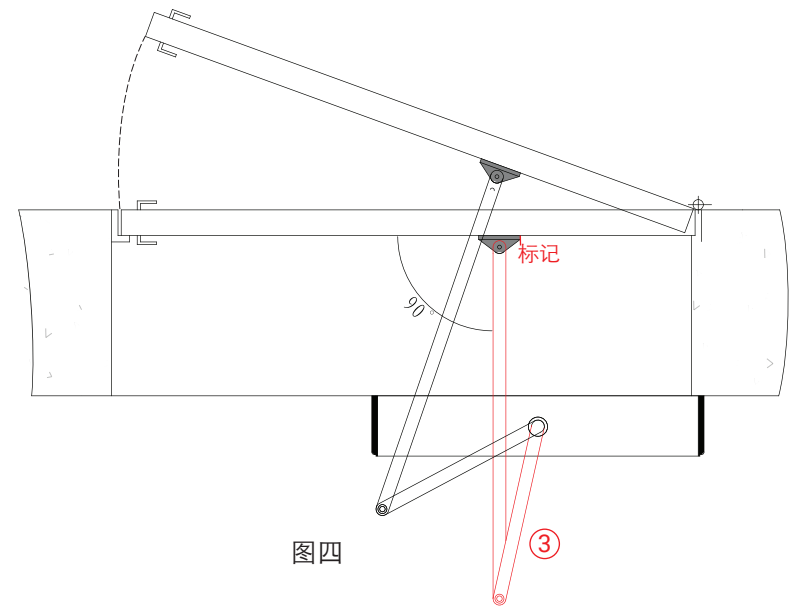

Figure 3

Step 1: according to the actual situation of the door body, open the screw hole position according to the hole drawing, as shown in Figure 1.

Step 2: put the door opener into the door frame, align the already punched screw holes, and fix them with screws, as shown in Figure 2.

Step 3: fix the push arm on the door opener, as shown in Figure 3.



图四

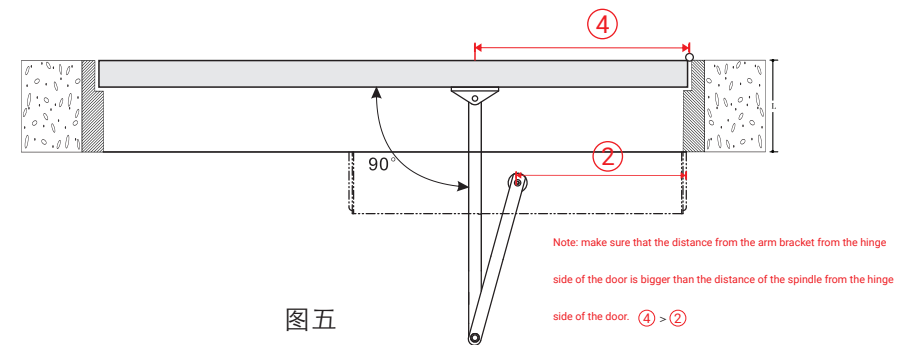

图五

Step 4: when the door is closed, ensure that the arm is perpendicular to the door, as shown in Figure 4, and fix the other end of the arm. (Note: installation precautions are shown in Figure 5)

Step 5: install the door opener cover and other accessories, download the app, and see the product commissioning instructions for commissioning.

Product introduction

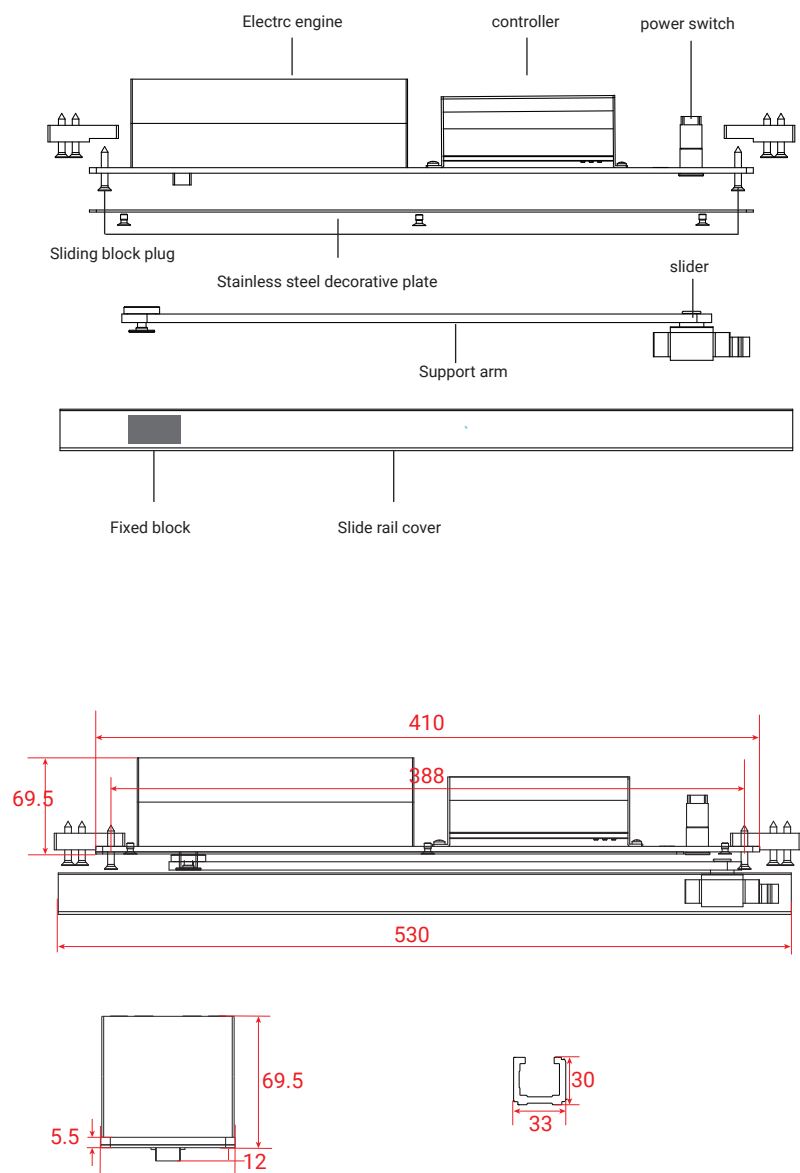

Section of main engine

Slide rail section

Installation guide for concealed door opener

Opening size of door frame (Unit: mm)

Single door (Opening drawing of wooden door)

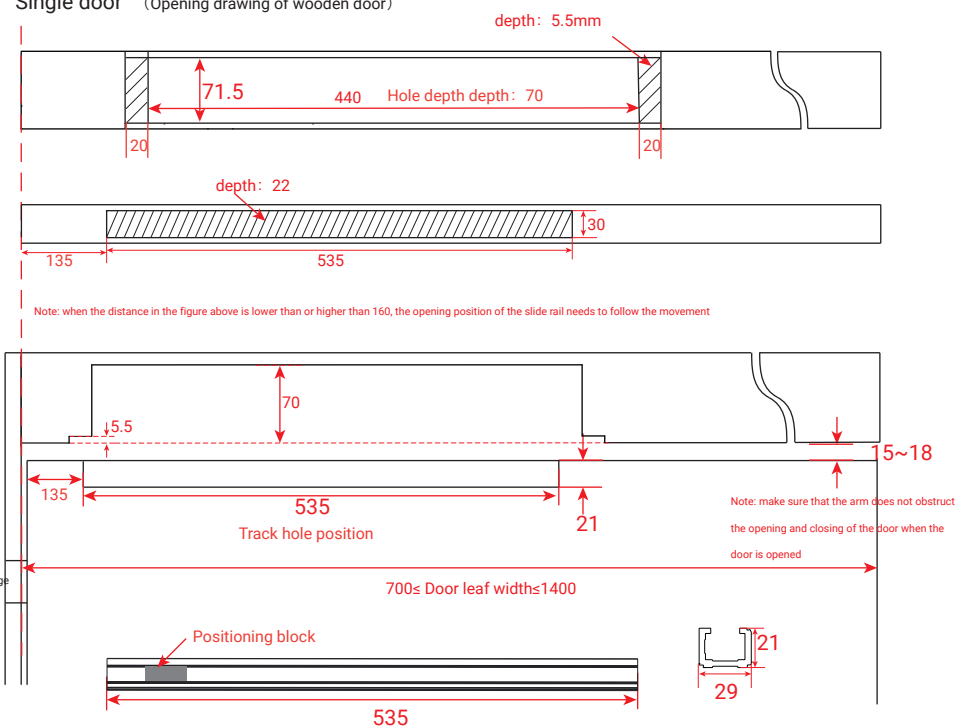

Installation steps of door opener

1. the hole position shall be reserved according to the above dimensions, as shown in the figure above.
2. connect the power cord, put the door opener in position within the door frame, and fix the door opener with screws (including stainless steel decorative plate).
3. put the sliding block and positioning block into the track (as shown in the figure), then put the track into the track hole of the door leaf, fix the screws, open the door to the required angle, and fix the positioning block to prevent the door from continuing to open.
4. fix both ends of the support arm on the sliding blocks of the door opener and the slide rail respectively, and fix them with screws.

single door (Metal door opening drawing)

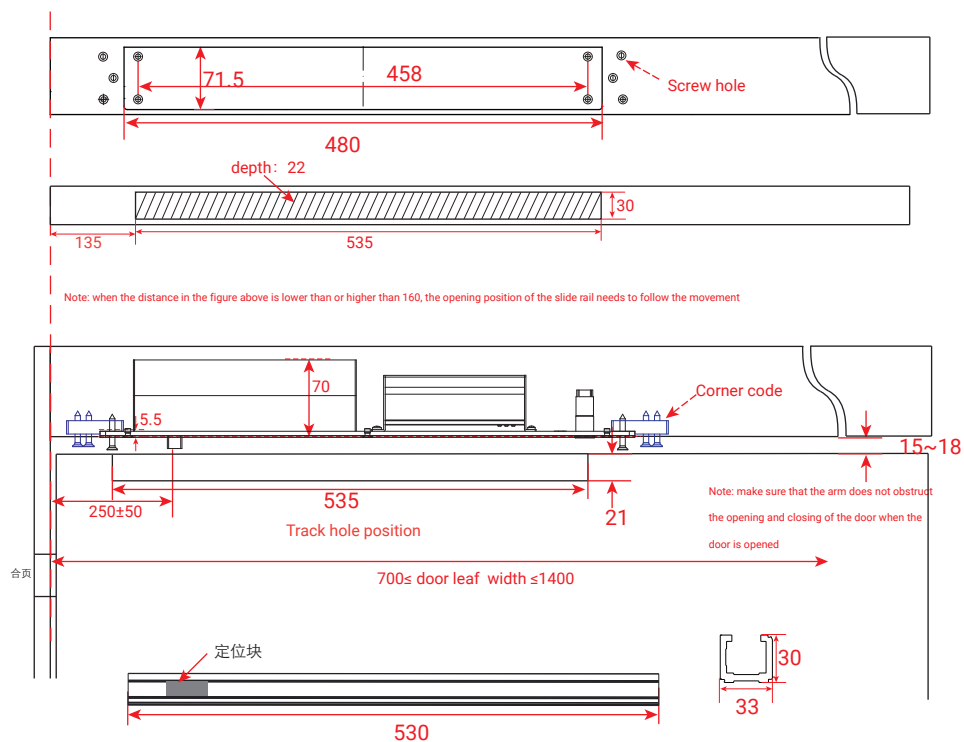

Installation steps of door opener

1. the hole position shall be reserved according to the above dimensions, as shown in the figure above.
2. install the installation brackets, connect the power cord, put the door opener into the hole of the door frame, fix it on the brackets, and install the stainless steel decorative plate.
3. put the sliding block and positioning block into the track (as shown in the figure), then put the track into the track hole of the door leaf, fix the screws, open the door to the required angle, and fix the positioning block to prevent the door from continuing to open.
4. fix both ends of the support arm on the sliding blocks of the door opener and the slide rail respectively, and fix them with screw.

Double door (Note: the metal door shall be fixed with foot code)

Double door opening size refers to single door opening size

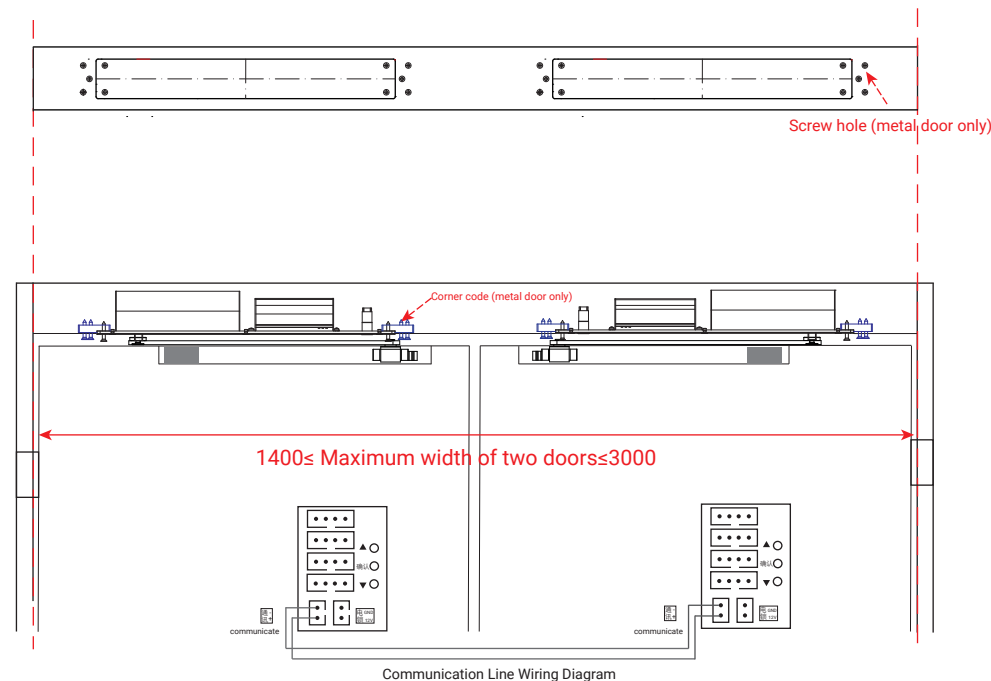



Installation steps of door opener

1. the hole position shall be reserved according to the above dimensions, as shown in the figure above.
2. connect the two door openers to the power line and the double door communication line, then put the door openers into the holes of the door frame, and fix the door openers with screws. (including stainless steel decorative plates)
3. put the sliding block and positioning block into the track (as shown in the figure), then put the track into the track hole of the door leaf, fix the screws, open the door to the required angle, and fix the positioning block to prevent the door from continuing to open.
4. fix both ends of the support arm on the sliding blocks of the door opener and the slide rail respectively, and fix them with screws.

Commissioning of single door opening equipment (determine the opening direction and starting point)

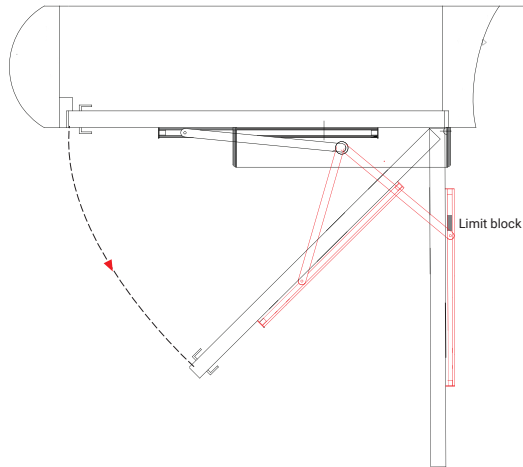
First step: After the door opener is installed, the door is opened to about 45°. (as shown below)



The second step: Determine the end position, place an obstacle to limit the opening angle to the desired position, open the app and press "open button"  start journey learning. (See app add equipment process)

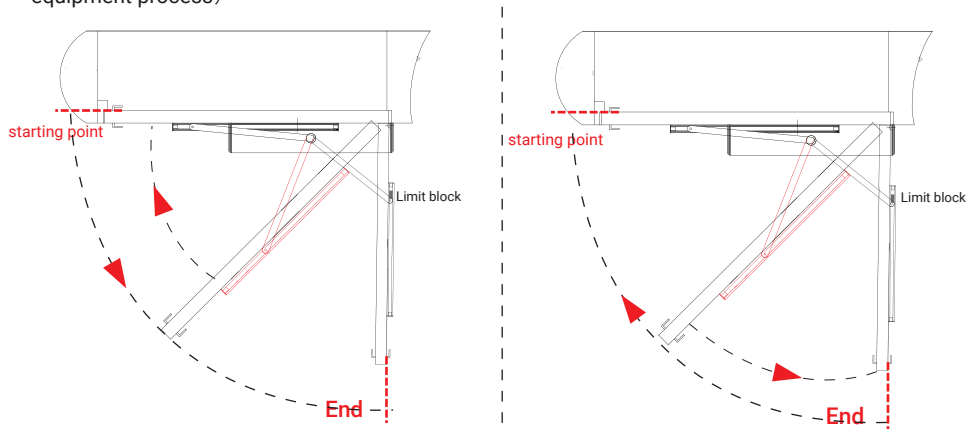



When the door moves towards the starting position, wait until the door has completed the starting and ending positions; The door needs to be reversed. Click app **advanced setting-Door opening direction**. **Select the opposite direction**. (See app operating instructions for details)

When the door moves towards the end position, wait until the door has finished the end and start position.

Commissioning of double door equipment

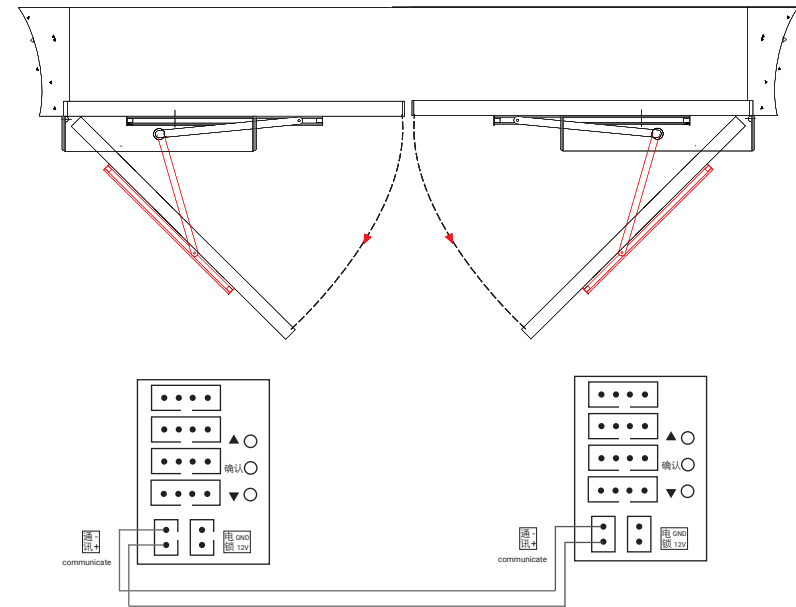
1. Double door without stop



1. Install 2 door openers
2. Connect the two door openers with communication cables, as shown in the figure
3. Open the mini program to add a device. The mini program sets the device that opens the door first as the host, and the other as the slave. (Note: Method for determining the host and slave: When opening the door, the automatic door opener that opens the door first is the host. The setting method can be found in the mini program operation method)
4. Open the mini program, open the host app interface, and click  note: manually open the two doors by about 30°, as shown in the above figure). Regardless of whether the main door starts to move towards the opening or closing direction, a block needs to be set at the endpoint position. The door opener will automatically move in reverse to another stop point. After the main door learning is completed, the slave door will automatically learn without blocking. Once the two doors are closed, the travel learning will be completed

2. Double door without stop

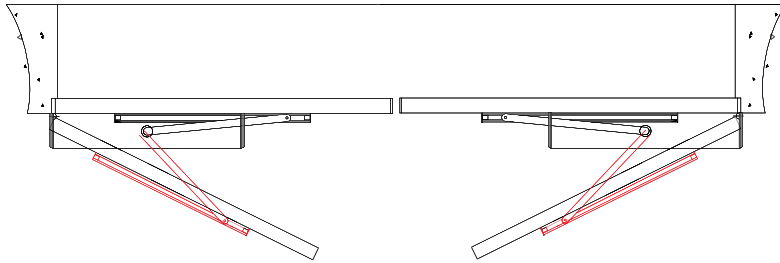

Method 1: (Two door openers run separately)

1. Install 2 door openers.
2. Add 2 door openers to the mini program, click to start, and then follow the single door debugging method for stroke learning, reversing, and other settings.
3. Connect the access control or sensing equipment to two door openers, as shown in the above figure, to achieve simultaneous door opening; When a single door opening is required, only one of the door opening machines needs to be turned off..



Method 2: (Two door openers operate in linkage)

1. Install 2 door openers.
2. Connect the two door openers with communication cables, as shown in the figure above
3. Open the mini program to add a device. The mini program sets the device that opens the door first as the host and the other as the slave.

3. Open the mini program to add a device. The mini program sets the device that opens the door first as the host, and the other as the slave. (Note: Method for determining the host and slave: When opening the door, the automatic door opener that opens the door first is the host. The setting method can be found in the mini program operation method)
4. Open the mini program, open the host app interface, and click . Note: manually open the two doors by about 30°, as shown in the above figure). Regardless of whether the main door starts to move towards the opening or closing direction, a block needs to be set at the endpoint position. The door opener will automatically move in reverse to another stop point. After the main door learning is completed, the slave door will automatically learn without blocking. Once the two doors are closed, the travel learning will be completed

3. Method of switching between dual and single mode when two machines are linked

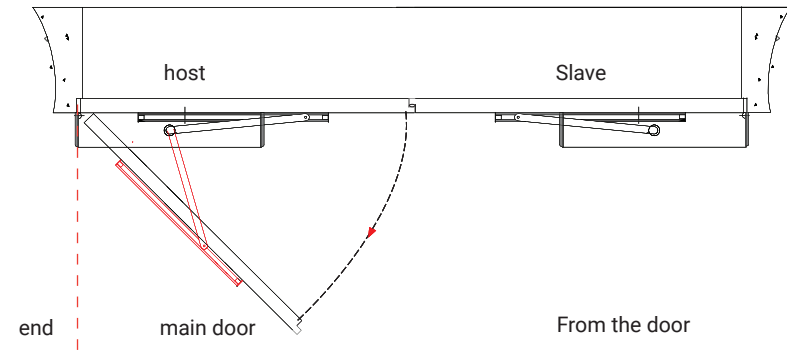

1. Switching between double door mode and single door mode

When the double door mode needs to be switched to single door mode, first power off both devices, and then turn on the host to achieve single door mode

2. Restore double door mode

When the single door mode needs to be switched back to the double door mode, first turn off the power of the host, then turn on the power of the slave, and then turn on the power of the host to restore the double door mode

How to use the remote control

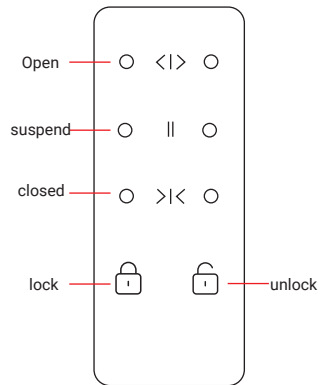

Method of adding button remote control

Method 1: Press the button on the motor, wait for the machine to sound "beep... beep...", quickly press the pause button on the remote control to complete remote control matching.

Method 2: Open the mini program and wait for the device to successfully pair with the mini program. Click on **【More】**, click on **【Add Remote Control】**, and wait for the machine to sound "beep... beep...". Quickly press the pause button on the remote control to complete remote control matching.

Remote Control Function Description

Press and hold the **【On】** button for 5 seconds to set the device to the normally open mode. At this time, the door leaf will be in the open mode, and external devices such as access control and microwave induction cannot be used.

Press and hold the **【On】** button again for 5 seconds to turn off the normally open mode

How to use the operation buttons

SN	function	Adjustable range	Function Description	Operation method
1	Door opening speed range	1-3	The larger the value, the faster the door opening speed	Up and down keys to select content → Press the middle key to enter options → Press up and down keys to debug → Press the middle key to exit
2	Door opening buffer distance	1-10	The larger the value, the longer the buffer distance for opening the door	
3	Door closing speed range	1-3	The higher the value, the faster the door closing speed	
4	Door closing buffer distance	1-10	The larger the value, the longer the door closing buffer distance	
5	Maximum speed range	3-10	The higher the value, the faster the door opening and closing speed	
6	Low speed buffer distance	0-15	The larger the value, the longer the buffer distance for opening and closing the door	
7	Door opening buffer speed	1-5	The larger the value, the slower the buffering speed when opening the door	
8	Door closing buffer speed	1-5	The larger the value, the slower the buffering speed when opening the door	
9	Deceleration distance	1-10	The larger the value, the longer the buffer distance for opening and closing the door	
10	Resistance sensitivity	1-5	The larger the numerical value, the greater the force of returning when the door is obstructed	
11	electric lock	0-1	0: Turn off the electric lock; 1: Unlock the electric lock	
12	Door opening dwell time	0-30	The dwell time for opening the door is adjustable from 0 to 30 seconds	
13	Main door direction:1	Reverse door opening: 0	Door opening direction switch	
14	Normally Closed Mode: 2	Normally open mode: 1	Jog mode: 3	
15	One pressure normally open	0-1	After opening the door in place, press the door that is closing for more than 3 seconds, and keep the door open once	
16	Journey learning	0-1	Delete and learn itinerary; 0: no itinerary; 1: With itinerary	(0: No travel) Up and down keys to select content → Press the middle key to enter options → Press the key to learn the travel → Auto exit (1: With travel) Up and down keys to select content → Press middle key to enter options → Press up key to delete travel → Auto exit
17	Door opening retention force	1-8	The larger the value, the greater the force required to hold the door in place after opening it	Up and down keys to select content → Press the middle key to enter options → Press up and down keys to debug → Press the middle key to exit
18	Door closing retention force	1-8	The larger the numerical value, the greater the force to press the door firmly after closing it in place	
19	Door closing impulse	0-5	The higher the numerical value, the greater the force required to quickly and forcefully close the door to the last 5 degrees	
20	Door closing impulse angle	1-4	The larger the numerical value, the greater the angle at which the door is quickly and forcefully slammed to the end	
21	Arm door	0-1	0: Direct drive door for machine without support arm; 1: Door driven by support arm	
22	Single door: 0	Double door: 1	Single door mode and double door linkage mode	
23	Slave: 0	Host: 1	The one that opens the door first is the host, and the one that opens the door later is the slave	
24	Slave stroke	-15-0-15	Increase the opening angle of the slave door by 1-15, and decrease the slave angle by -1-15	
25	Door opening linkage time	0-7	Adjustment of the interval time for the sequence of opening doors	
26	Closing linkage time	0-3	Adjustment of the interval time of the closing sequence	
27	Light door: 0	Heavy Duty Door: 1	Switching between light and heavy door modes	
28	Add A remote control	0-5	Add remote control	
29	Add B remote control	0-5	Add remote control	Up and down keys to select content → Press the middle key to enter options → Press up and down keys to confirm → Auto exit
30	Clear remote control	/	Clear all remote controls	Up and down keys to select content → Press the middle key to enter options → Press up and down keys to confirm → Auto exit
31	Restore factory settings	/	Restore parameters to factory settings	Up and down keys to select content → Press the middle key to enter options → Press up and down keys to select content → Press the middle key to enter options → Press up and down keys to switch → Auto exit
32	Font direction	0-1	Font switching between positive and negative directions	Press down to select content → Press middle to enter options → Press up and down to debug → Press middle to exit
33	Reaction sensitivity	1-10	The higher the response sensitivity value, the greater the force of static start and low-speed buffering	Up and down keys to select content → Press the middle key to enter options → Press up and down keys to select content → Press the middle key to enter options → Press up and down keys to switch → Auto exit
34	English	Chinese	Chinese and English subtitle switching	
35	SN NisNiu 230823	/	Hardware Version	
36	平开-60M-58	/	Application Type	
37	ER-230921	/	Program version number	

Slave travel: Hold the remote control and press the unlock button for 5 seconds without releasing it. After the red light on the remote control flashes, press the open door button again to increase the slave's door opening angle (increasing the door opening angle with each press), and press the close door button to decrease the door opening angle (decreasing the door opening angle with each press) (the unlock button cannot be released when the open and close door button is pressed).